

Hydraulics & pneumatics

A Penton Publication

SERVING FLUID POWER AND MOTION CONTROL ENGINEERS WORLDWIDE

In this issue

Walking on air

**Stop leaks in
their tracks**

Spotlight on seals

**Hydraulics
plays
Hard Rock**

www.hydraulicspneumatics.com

Rotary actuators do triple duty

Components serve as rotating device, mounting bracket, and bearing support in hard rock drilling machine

The Tamrock Axera 226 — built in Lyon, France, by Sandvik Mining and Construction — is a rubber-tired, twin-boom rock-drilling machine. Typically used for underground hard-rock mining and tunneling applications, the machine is designed to drill a series of holes in the face, sides, roof, and floor of a chamber without being moved. It can produce cross-sectional areas between 6- and 40 m² from one position. Depending on the application, rock bolts or explosives are inserted into the holes. With the drills located at the outboard ends of the booms, the risk of injury to the operator and damage to the main machine from falling rock and debris is minimized during the drilling operation.

Power comes from a Deutz BF4M2012 diesel engine that delivers 74 kW (100 hp). The rig carries twin 55-kW hydraulic power units that produce 18 to 24 kW of percussive power. A drill mechanism uses a combination of percussion and rotation of the drill bit. A manually operated, hydraulically controlled drilling system — with multiple automatic functions — allows high drilling performance with good drill-steel economy and high reliability.

The dual-boom design extends the time period between drill-bit changes. In addition, one boom can work while the other is being set up. A series of rugged cylinders coordinates the X-Y boom movements and manipulates the feed, making control of the drill simple and logical. Each boom includes a 360° helical rotary actuator that helical rotary actuator that enables the operator to roll the feed beam over to drill into face, side, roof, and floor surfaces. The actuator also can position the feed for full visibility over the top of the feed and the drill bit.

Helac Corp., Enumclaw, Wash., manufactures the Model L30-95-S-RL-360-L1-C-H helical rotary actuators.

Courtesy, Sandvik Tamrock Secoma SAS

Tamrock Axera 226 — known in its industry as a **Jumbo** — has a 4-wheel drive, center-articulated carrier that makes it highly maneuverable in confined spaces. Large tires and high ground clearance enable operation on uneven and wet surfaces.



Twin booms, with drill heads on outboard ends, improve production.

The rotary actuators are integral parts of the machine, mounted in-line between the booms and drill heads. Their large, circular, integral shaft flange — with drilled and tapped bolt circle — is used to attach the actuator to the boom.

The drill head assembly is attached to the actuator's octagonal rear mounting flange. The actuator's shaft remains stationary with the boom while the housing and drill head rotate. (The actuator also incorporates a drilled and tapped mounting rail on the housing. Sandvik uses the rail mounting style for other rotating applications.)

Helac Corp., Enumclaw, Wash., manufactures the Model L30-95-S-RL-360-L1-C-H helical rotary actuators. The rotary actuators are integral parts of the machine, mounted in-line between the booms and drill heads. Their large, circular, integral shaft flange — with drilled and tapped bolt circle — is used to attach the actuator to the boom.

The drill head assembly is attached to the actuator's octagonal rear mounting flange. The actuator's shaft remains stationary with the boom



Model L30-95-S-RL-360-L1-C-H rotary actuator has drilled and tapped mounting rail on the housing. Sandvik uses the rail mounting style for other rotating applications.

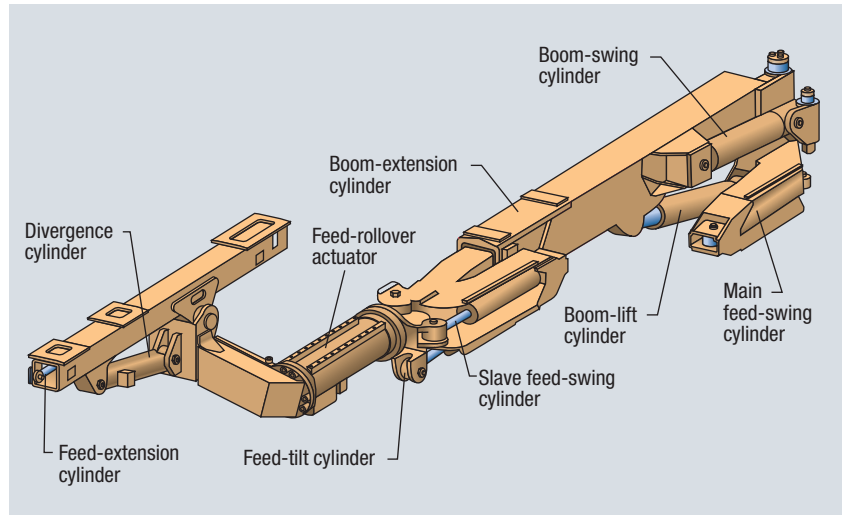

Model B 26 F OF boom on Axera 226 combines series of cylinders and helical rotary actuator for accurate positioning of drill head.

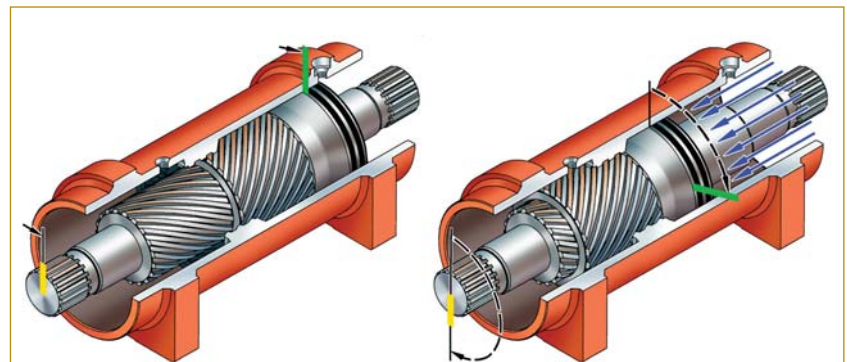

Helical actuators are composed of a housing and only two moving parts: a central through shaft and an annular piston. As hydraulic pressure is applied, the piston is displaced axially, while the helical gearing on the piston OD and housing's ring gear cause the simultaneous rotation of the piston. At the same time, gearing on the piston ID and shaft causes the shaft to rotate.

while the housing and drill head rotate. (The actuator also incorporates a drilled and tapped mounting rail on the housing. Sandvik uses the rail mounting style for other rotating applications.)

The unique characteristics of the helical rotary actuator make it ideal for this application. Its sliding-spline operating concept (see boxed description) produces very high output torque (in this case: 90,000 lb-in. at 3000 psi) from a compact configuration. The actuator measures 33 in. in overall length with an 8-in. housing diameter. It weighs 415 lb.

Because all spline teeth remain engaged at all times, loads are equally distributed over the teeth. This results in exceptional durability and high tolerance to the shock loads inherent in rock drilling. Backlash is almost negligible — approximately 1°. Helac's patented integral bearing design enables the actuator to support heavy

radial, moment, and thrust loads without the need for additional, external bearings.

In the Axera 226 machine, one actuator supports the entire drill head assembly on each boom. Because all sealing occurs against smooth, cylindrical surfaces, internal by-pass and external leakage has effectively been eliminated, resulting in smooth positioning capabilities and zero drift after a position has been selected. The actuator has an integral dual counterbalance valve that further improves positioning accuracy and adds an extra margin of safety in case of system failure. In short, the helical rotary actuator functions as rotating device, mounting bracket, and bearing support — all in one component.

For more information on rotary helical actuators, call (360) 825-1601 or visit www.helac.com.